

# OPERATION MANUAL



## RK-2006LPP

AUGER FITTED SOLID FUEL  
BOILER TEMPERATURE CONTROLLER

Version DC19



## 1. Application.

Controller RK-2006LPP is designed for temperature control of solid fuel fired water boilers equipped with::

- Auger and feeding stoker working with the stoker,
- Blow-in fan,
- Ignition glow plug for automatic start,
- Central heating pump,
- Hot tap water pump or mixing pump (option),
- Alarm indicator or or ash removal system (option),
- Room thermostat (option).

## 2. Connection.

Before turning on the controller, connect: power cables of: controller, blow-in fan, central heating and hot tap water pumps and auger to appropriate sockets in the rear of the controller. The temperature sensor should be placed in metering locations that shall be dry. Figure 2 presents the electrical connection diagram. For connection of stoker, alarm indicator and ash removal system the additional module UM-1 shall be applied.

**CAUTION!** Before plugging in the controller first check if the wiring system is properly grounded, and if the terminal screws of the output connector are tightened.

**CAUTION!**Total power of the fan, central heating and hot water pump which are connected to the controller must not exceed 900W. Outputs of the controller that are not used may remain disconnected.

**CAUTION!** Control outputs of the feeder and lighter are not protected and **MUST BE** protected with adequate fuses.

**CAUTION!** The controller is equipped with properly protected semiconductor temperature sensors, yet metering locations with installed sensors must be dry.

**CAUTION!** It is not allowed to connect the room thermostat and other sensors inputs to power supply.

### 3. Operation.

After turning the controller on, the name and software version is displayed and all signal lamps are on to enable checking of functionalities. When the controller is turned on it will return to its last state before turning off or power failure.

On the front panel of the controller (Figure 1) there is:

- 1 - Display,
- 2 - Fan indicator,
- 3 - Auger indicator,
- 4 - Ignition glow plug indicator,
- 5 - Central heating circuit pump indicator,
- 6 - Hot tap water pump or mixing pump indicator,
- 7 - Room thermostat operation and boiler desired setting indicator,
- 8 - Previous parameter selection button,
- 9 - STOP button for alarm and settings change cancellation,
- 10- START button,
- 11- Next parameter selection button,
- 12- Boiler thermostat and parameters setting knob with OK confirmation button.



Figure 1. Front panel of RK-2006LPP controller.

### 3.1. Main window, adjustment mode and devices mode.

Following turning on of the controller the main window is displayed. On the top of the display (1) boiler water temperature is shown, and on the bottom operation mode is displayed. Symbol „\*” displayed in the right bottom corner indicates burner flame detection. Lights below the display indicate particular outputs and when switched on they indicate their operation.

BOILER TEMP . 1 6 7 c
STOP *

Basic operation of the controller is carried out by setting the desired temperature of the boiler. To do this turn the boiler thermostat knob (12) according to the desired setting and confirm with OK button (Press the knob).

DESIRED BOILER TEMPERATURE → 1 5 8 c
--------------------------------------

**CAUTION!** If the heating system is fitted with the domestic water tank, boiler water temperature controlled and maintained by the controller during tank preheating may be higher than desired temperature setting programmed with thermostat’s knob.

### 3.2. Device operation modes.

Table 1. Operation mode list.

Operation mode.	Description
STOP	Boiler control stopped. Controller maintains central heating and domestic water pump operation, but automatic ignition does not follow.
STAND-BY	Controller maintains central heating and domestic water pump operation. In case of heat demand automatic ignition of boiler follows.
IGNITION	Controller carries out automatic ignition of boiler.
MAX. POWER	Fan and fuel feeder operates to reach boiler max. power.
MODUL. POWER	Controller reduces fuel feeding as much as boiler water temperature corresponds to the desired setting.
MINIMUM POWER	Fan and fuel feeder operation is minimize to maintain fire.
SCAVENGE (AIR PURGING)	Controller activates blower to ensure removal of accumulated gases.
EXTINCTION (SHUT DOWN)	No heat demand or ash removal needed. Controller shuts down boiler operation.
CLEANING	Burner cleaning.
AUGER (MANUAL) REFILLING	Manual operation of fuel auger. Boiler control stopped. Controller maintains central heating and domestic water pumps operation, but automatic ignition does not follow.
AUGER EXTINGT (EMERGENCY SHUT DOWN)	Fuel ignition in auger channel. The controller empties ignited fuel from the auger channel until temperature drops.
ALARMS	Safety and temperatures sensors failure alarms.

**STOP.**

Controller maintains central heating and domestic water pumps operation only to protect the boiler against overheating and auger channel ignition. Room thermostat contacts closing (call for heat) and domestic water temperature drop do not result in any action. Pressing START button (10) will result in switching the controller to STAND-BY mode.

**STAND-BY.**

In this mode controller does not carry out any additional operation, until room thermostat contacts close (call for heat) or domestic water temperature drop, the boiler operation will focus on maintenance of temperature according to thermostat setting programmed with the knob. If preheating of domestic water tank is necessary and the desired boiler temperature setting is higher from domestic water temperature setting the controller will follow higher setting. Pressing the STOP button (9) will result in switching to STOP mode.

**IGNITION.**

Boiler controller is switched into IGNITION mode if demand for heat follows, and if the controller did not detect the flame. During ignition the controller activates fan, auger and igniter. Fuel and air feeding rate is adjusted by the technician. IGNITION mode follows till flame is detected. If the flame is not detected within the specified time, the controller activates „Out of fuel alarm“. Pressing STOP button, exceeding time limit for cleaning, thermostat contacts opening or if water temperature in domestic water tank is obtained during operation in IGNITION mode will result in switching of the controller into EXTINCTION (SHUT DOWN) mode.

**MAX. POWER OPERATION MODE.**

When in this mode the controller operates fuel auger and fan to ensure max. power of the boiler. Fuel and air feeding rate is adjusted by the technician. Pressing STOP button, exceeding time limit for cleaning, thermostat contacts opening or if water temperature in domestic water tank is obtained during operation in MAX. POWER mode will result in switching of the controller into EXTINCTION (SHUT DOWN) mode.

**MODULATED POWER OPERATION MODE.**

Depending on desired parameters the controller may gradually reduce fuel and air rate feeding to reduce burner power, as much as boiler water temperature corresponds to the programmed setting. Pressing STOP button, exceeding time limit for cleaning, thermostat contacts opening or if water temperature in domestic water tank is obtained during operation in MODULATED POWER mode will result in switching of the controller into EXTINCTION (SHUT DOWN) mode.

### **MINIMUM POWER OPERATION MODE.**

When in this mode the controller operates fuel feeding and fan operation to maintain firing to ensure the minimum fuel consumption. Fuel and air feeding rate is adjusted by the technician. If in spite of boiler minimum power, increase temperature follows of water temperature in relation to the top hysteresis parameter setting, the controller will be switched into EXTINCTION(SHUT DOWN) mode. When the boiler water temperature drops below the desired setting it will result in switching of the controller into „max power operation mode”. Pressing STOP button, exceeding time limit for cleaning, thermostat contacts opening or if water temperature in domestic water tank is obtained during operation in MINIMUM POWER mode will result in switching of the controller into EXTINCTION (SHUT DOWN) mode.

### **SCAVENGE (AIR PURGING).**

During operation with minimum power the controller will activate scavenge to ensure removal of accumulated gases. Scavenge is provided with temporary fan operation.

### **EXTINCTION (SHUT DOWN).**

When in this mode the controller turns off the fuel auger and engages the fan to ensure complete fuel combustion and the burner cool down. Fan power when in EXTINCTION (SHUT DOWN) mode is determined by the technician. When EXTINCTION (SHUT DOWN) is finished the controller is switched into CLEANING, STAND-BY or STOP mode, provided EXTINCTION (SHUT DOWN) followed as a result of STOP button pressing.

### **CLEANING.**

Automatic burner cleaning occurs after time set limit by programmer. In this mode controller starts cleaning system for preset time. After this procedure controller resets back to STANDBY mode.

### **AUGER (MANUAL) REFILLING.**

User may activate auger manual refilling function. When device is in STOP mode, press START and hold button for 5 seconds to start refilling. Refilling follows according to the time programmed by the technician or until it is manually turned off with STOP button.

### **AUGER EXTINCTION (EMERGENCY SHUT DOWN).**

If the auger is equipped with temperature sensor, a temperature increase above the range programmed by the technician it will result in activation of auger ignition alarm. If ignition was detected, the controller turns off the fan and auger. If the burner is provided with the stoker, the device is switched additionally into AUGER EXTINCTION (EMERGENCY SHUT DOWN) mode. During shut down the stoker is engaged for the time needed to remove the fired fuel from the stoker.

### 3.3. ALARMS.

RK-2006LP controller continually checks operations of installed devices as well as alarm sensors. In case of failure, the device activates alarm and proper operations are carried out. Information on the problem is also shown on the display. In addition depending on nature of damage the inner sound alarm system may be activated. To cancel alarm, first identify the cause and repair it and then STOP button shall be pressed. If alarm is cancelled and required repairs did not follow, sound alarm system will be turned off only. In case more than one alarm has been activated, information on each alarm will be displayed alternately.

#### Out of fuel alarm.

If in IGNITION mode the controller fails to detect a flame within the time specified by the technician, „Out of fuel alarm” will be activated. To turn on the controller again first refill fuel, cancel the alarm with STOP button and begin setting-up process by pressing START button.

A L A R M :    O U T   O F F U E L
---------------------------------------

#### Emergency alarm.

Depending on construction type, the boiler may be equipped with emergency sensor (e.g. hopper cover sensor). Activation of the alarm will result in fan and auger turning off, and switching the controller into STAND-BY mode.

A L A R M :    E M E R G E N C Y I N P U T
---

**CAUTION!** This alarm does not result in engagement of inner sound system and does not require cancelling. Once the hopper cover is closed, the programmed process will be carried out from the moment when it was interrupted (it returns to the mode that was before alarm activation).

#### Auger ignition alarm.

If the auger has been fitted with temperature sensor, and the programmed setting of „Auger ignition temperature” was exceeded, it will result in activation of „Auger ignition alarm”. The controller will switch off the auger, fan and igniter. If the burner is fitted with secondary stoker, the device will be switched into AUGER EXTINCTION (EMERGENCY SHUT DOWN) mode.

A L A R M :    A U G E R I G N I T I O N
---

**CAUTION!** This alarm may be cancelled only if the auger temperature drops below set point. If the alarm was cancelled before extinction completion, only sound alarm will be turned off.



BOILER TEMP. 60 C
AUGER EXTINGT.

**Auger sensor damage.**

In case of auger temperature sensor damage, as in case of overheating, the controller will go to shut down mode and will activate the appropriate alarm:

ALARM : AUGER
TEMP. SENSOR

**CAUTION!** This alarm may be cancelled only after repairs.

**Burner temperature sensor damage.**

If flame temperature detector (CT-1/2 or PT-1000) has been connected to the controller, its damage will result in activation of the alarm and switching into STAND-BY mode.

ALARM : BURNER
TEMP. SENSOR

**Protection against boiler overheating.**

RK-2006LPP controller is provided with triple protection against boiler overheating. If boiler water temperature set point is equal to the programmed „Boiler max. temperature” service setting, the controller will engage central heating pump.

If water boiler temperature increases above 93°C, it will activate STB system which will automatically engage power for central heating pump and will shut off blower. Operation of STB will result in switching the controller to STAND-BY mode. Normal operation of STB will be resumed, if boiler temperature drops below 90°C.

Boiler water temperature increases up to the programmed „Boiler overheating temperature” service setting will result in fan turning off, engagement of central heating pump and switching the controller in STOP mode, but EXTINCTION (SHUT DOWN) mode and alarm will not be activated:

ALARM : BOILER
OVERHEAT

**CAUTION!** This alarm may be cancelled, if boiler water temperature drops below the overheating temperature setting.

**Boiler temperature sensor damage.**

In case of boiler water temperature sensor damage the controller turns off the fan, engages central heating pump, controller switches into STOP mode and activates alarm:

A L A R M :    B O I L E R
T E M P .       S E N S O R

**CAUTION!** This alarm may be cancelled, only if repairs are made.

**Domestic water temperature sensor damage.**

If the heating system is fitted with domestic water circuit, in case of sensor damage the controller turns off the domestic water pump and activates alarm:

A L A R M :    H O T   W A T E R
T E M P .       S E N S O R

**CAUTION!** This alarm does not require cancellation. The alarm is deactivated automatically, if repairs are made.

**Return water temperature sensor damage.**

If the heating system is provided with the mixing pump, in case of return water temperature sensor damage, the pump is switched off and the controller activates alarm:

A L A R M :    R E T U R N
T E M P .       S E N S O R

**CAUTION!** This alarm does not require cancellation. The alarm is deactivated automatically, if repairs are made.

**4. Review of user settings.**

Pressing parameter buttons (8 and 11) allows reviewing user’s parameters while their activation is indicated with fast flashing of proper light. Following selection of the desired parameter you can switch to the change mode by pressing OK button (12) (indicated with the displayed symbol „→” on the left of the desired parameter). You can confirm new settings by pressing OK button. Press the STOP button to exit the change mode and resume the previous setting of the parameter. If the device was left in the change or parameters previewing mode for 60 seconds and no button was pressed, the controller will automatically cancel the last modification and will be switched into display mode. Table 2 presents user’s settings. Columns of the table represent: fast flashing light, parameter name and available minimum and maximum setting.

Table 2. User settings list.

Light	Parameter	Min.	Max.
Auger	Fuel type.	1	4
Thermostat	Desired boiler temperature.	100°C	300°C
	Boiler max. power.	60%	100%
CH pump	Central heating pump operation mode.	WINTER	SUMMER
HTW pump	Domestic water desired temperature.	30°C	60°C
	Domestic water heating priority.	NO	YES
	Domestic water tank bacterial flora liquidation program.	NO	YES
	Measured domestic water temperature.		
Igniter	Measured return water temperature.		
	Current furnace brightness (FD-1).		
	Brightness when fuel ignition has occurred (FD-1).	0	255
	Temperature of the burner (PT-1000, CT-1/2).		
	Burner temperature with fuel ignited (PT-1000, CT-1/2).	20°C 20°C	500°C 100°C
	Burner work time.		
	Burner start up counter.		

#### 4.1. Fuel type selection.

RK-2006LPP controller enables programming ignition settings for four different fuel types. „Fuel type” parameter enables switching between particular settings. Fan, auger and igniter operation are saved for the selected fuel type.

FUEL TYPE	1
--------------	---

**CAUTION!** Fuel type may be changed, if the controller is in STOP mode only.

#### 4.2. Boiler temperature setting.

**Desired boiler temperature** - it is the temperature setting that will be obtained by the controller, if room thermostat input contacts are closed.

DESIRED BOILER TEMPERATURE	150 c
-------------------------------	-------

#### 4.3. Boiler operation max. power.

**Boiler operation max. power** - this parameter enables to limit boiler operation max power. Power limitation is possible thanks to fuel reduction during operation at maximum power.

MAXIMUM BOILER POWER	100 %
-------------------------	-------

**4.4. Domestic water circuit operation parameters.**

These parameters specify how the controller ensures domestic water temperature. In case of the system without domestic water circuit, it is not possible for the user to view and change these parameters.

**Domestic water desired temperature** - parameter that specifies temperature of water in domestic water tank that will be obtained by the controller.

DESIRED H. WATER
TEMPERATURE 50 c

**Domestic water heating priority** - this parameter specifies operation of central heating and domestic water pumps during hot water preheating. When priority is selected during operation and hot water preheating, the controller engages domestic water pump and switches off central heating pump. This operation results in quick heating of water in the tank. During preparation of hot water without priority option, central heating and domestic water pumps operation follow at the same time.

HOT WATER
PRIORITY NO

**Bacterial flora liquidation in domestic water tank** - the controller enables manual activation of program for bacterial flora liquidation in domestic water tank. When „YES” is selected, it activates the process of heating the domestic water tank above 75°C. When the required temperature is obtained the controller switches off the bacterial flora liquidation program automatically.

BACTERIAL FLORA
LIQUIDATION NO

**CAUTION!** Bacterial flora liquidation option shall be switched on in the night or if water intake does not follow from the domestic water tank, to protect the user against burning.

**Domestic water measured temperature** - the controller enables to view the temperature measured in domestic water tank.

MEASURED H. WATER
TEMPERATURE 48 c

**4.5. Return water temperature.**

If the heating circuit is equipped with the mixing pump and return temperature sensor, this option enables view of the return water temperature. Otherwise, this option is unavailable.

MEASURED RETURN
TEMPERATURE 32 c

#### 4.6. Flame optical detection parameters.

These parameters specify operation of burner flame optical detector. If the system is fitted with flame temperature detector, parameters change and viewing is unavailable.

**The current furnace brightness determined by an optical detector** - this parameter displays the current flame brightness measured by the optical detector.

CURRENT FURNACE BRIGHTNESS	2 8
-------------------------------	-----

**Brightness when fuel ignition has occurred** - if the optical detector reading will be equal or higher than this desired setting, the controller will switch off the igniter and assume that ignition has occurred.

IGNITION OFF AT BRIGHTNESS	1 4
-------------------------------	-----

#### 4.7. Flame detection temperature parameters.

These parameters specify operation of the temperature detector of burner fuel ignition. If the system is fitted with optical fire burner detector, parameters change and viewing is unavailable.

**Burner measured temperature** - this parameter displays the current measured burner temperature.

MEASURED BURNER TEMPERATURE	6 6 c
--------------------------------	-------

**Burner temperature with fuel ignited** - if ignition temperature is equal or higher than this desired setting, the controller will switch off the lighter and assume that ignition was provided.

IGNITION OFF AT TEMPERATURE	2 0 0 c
--------------------------------	---------

#### 4.8. Information on burner work.

Parameters described below refer to counters that accumulate information on operation of the burner since its first start. It is not possible to cancel counter readings.

##### **Burner work time.**

Reading of this counter defines burner work time. The counter updating follows after total working hour of the device at maximum or minimum power.

BURNER WORK TIME	1 3 h
---------------------	-------

## Burner start up counter.

Reading of this counter defines start number of the ignition attempts.

BURNER START COUNT	8
-----------------------	---

## 5. Settings – service mode.

Holding OK button for 3 seconds enters the service mode where you can review and change the parameters by pressing the selection buttons (8 and 11). After selection of the given parameter you can enter into the change mode with OK button that is indicated by the displayed symbol „→” on the left of the desired parameter. Pressing OK button will confirm the change. If you press STOP button changes will not be saved and old settings will be resumed. If the device is in change mode or parameters reviewing for 60 seconds, the controller will automatically go back to the display mode. Table 3 presents the list of all service settings. Columns of the table represent: flashing light, parameter name and available minimum and maximum setting.

Table 3. Service settings.

Light	Parameter	Min.	Max.
No	Language selection (See description).		
Fan	Fan modulation during boiler start.	NO	YES
	Min. fan speed during heating up.	1%	100%
	Max. fan speed during heating up.	1%	100%
	Ignition modulation start delay.	0s	250s
	Fan speed during ignition.	1%	100%
	Fan speed at max. power.	1%	100%
	Fan speed at min. power.	1%	100%
	Fan speed at extinction.	1%	100%
	Fan speed during cleaning mode.	0%	100%
	Fan scavenge (air purging).	NO	YES
	Fan scavenge (air purging) blow time.	5s	60s
	Fan scavenge (air purging) pause time.	1min	99min
	Fan speed during scavenge.	1%	100%
Auger	Auger filling time.	1min	99min
	Initial fuel feed.	0s	250s
	Fuel feed cycle.	1s	250s
	Fuel feed during ignition.	0%	100%
	Fuel feed for max burner power.	1%	100%
	Fuel feed for min. burner power.	1%	100%
	Stoker work mode (See description).		
	Stoker work time.	1s	99s
	Stoker pause time.	1s	99s
	Stoker extra work time.	1s	99s
	Stoker emptying time.	1s	99s
	Auger ignition test.	NO	YES
	Auger ignition temperature.	20°C	99°C
Igniter	Flame detector type (See description).		
	Correction FD-1.	0	99
	Hysteresis loss of flame (optical sensor).	1	255

Igniter	Hysteresis loss of flame (temperature sensor).	1°C	250°C
	Flame failure detection delay.	1s	500s
	Fuel ignition time.	1min	15min
	Ignition try count.	1	10
	Furnace extinction time.	1min	30min
	Furnace cleaning mode (See description).		
	Cleaning mechanism work time.	1s	900s
	Cleaning mechanism retraction time.	1s	900s
	Cleaning mechanism pause time.	1s	900s
	Number shut downs before cleaning.	1	99
	Minimum operating time without cleaning.	0h	max-1h
Maximum working time without cleaning.	min+1h	99h	
CH pump	Central heating pump work mode (See description).		
	Central heating pump periodic work.	NO	YES
HTW pump	Central heating pump periodic work time.	1min	99min
	Domestic water path (See description).		
	Domestic water heating hysteresis.	1°C	20°C
	Boiler increase temperature during hot tap water heating.	2°C	20°C
	Domestic pump work extension.	NO	YES
	Domestic pump work extension time.	1min	10min
	Mixing pump engaging temperature.	30°C	60°C
Thermostat	Mixing pump work hysteresis.	1°C	9°C
	Boiler minimum temperature.	30°C	200°C
	Boiler maximum temperature.	200°C	400°C
	Boiler upper hysteresis.	1°C	20°C
	Boiler power switching hysteresis.	1°C	9°C
	Boiler protection hysteresis.	1°C	5°C
	Boiler overheating temperature.	301°C	420°C
	Burner power modulation.	NO	YES
No	Modulation factor.	1	20
	Resume service settings.		
	Outputs test.		
	Service mode end.		

### 5.1. Language selection.

RK-2006LPP controller interface offer the function of language selection. Number of available languages depend on software version being used.

L A N G U A G E	E N G L I S H
-----------------	---------------

### 5.2. Fan operation parameters.

**Fan modulation during boiler start** - selection of „YES” setting means that fan speed modulation will be provided during boiler start.

F A N M O D . D U R I N G	B O I L E R S T A R T Y E S
---------------------------	-----------------------------

**Min. fan speed during heating up** - this parameter is available, if the function of fan modulation during boiler start is selected. This parameter specifies power of the fan during boiler start.

MIN . FAN SPEED	
HEATING UP	1 %

**Max. fan speed during heating up** - this parameter is available, if the function of fan modulation during boiler start is selected. This parameter specifies power of the fan at end of boiler start.

MAX . FAN SPEED	
HEATING UP	6 0 %

**Ignition modulation start delay** - this parameter is available, if the function of fan modulation during boiler start is selected and it describes operation time of the fan with speed according to the selected „Min. fan speed during boiler start” setting. After time expire the controller will increase fan speed up to the selected „Max. fan speed during boiler start” setting.

IGNITION MODUL .	
START DELAY	5 0 s

**Fan speed during ignition** - this parameter describes power of the fan speed during ignition. This parameter is unavailable if „Fan speed modulation during ignition” was selected.

FAN SPEED DURING	
IGNITION	6 0 %

**Fan speed at max. power** - means the fan power when burner of the boiler works with maximum power.

FAN SPEED AT	
MAX POWER	6 0 %

**Fan speed at min. power** - means the fan power when burner of the boiler works with minimum power.

FAN SPEED AT	
MIN POWER	3 0 %

**Fan speed during extinction (shut down)** - means fan power during burner extinction (shut down).

FAN SPEED DURING	
EXTINCTION	1 0 0 %



**Fan speed during cleaning mode** - only when AUTO is on.

FAN SPEED DURING CLEANING	100%
------------------------------	------

**Fan scavenge (air purging)** - the controller offers the function of scavenge (air purging), which simply includes periodical switching on of the fan during burner operation for the purpose of removal of accumulated gases.

FAN SCAVENGE	YES
-----------------	-----

**Fan scavenge (air purging) blow time** - this parameter specifies blow time. This setting is unavailable if „Fan scavenge” (air purging) setting was not selected.

FAN SCAVENGE BLOW TIME	5 s
---------------------------	-----

**Fan scavenge (air purging) pause time** - this parameter specifies pause time during scavenge. This setting is unavailable if „Fan scavenge” (air purging) setting was not selected.

FAN SCAVENGE PAUSE TIME	1 min
----------------------------	-------

**Fan speed during scavenge (air purging)** - this parameter specifies fan power during scavenge (air purging). This setting is unavailable if „Fan scavenge” (air purging) setting was not selected.

FAN SPEED DURING SCAVENGE	100%
------------------------------	------

### 5.3. Fuel auger operation parameters.

**Auger filling time** - this parameter specifies time required for refilling the main auger with fuel.

AUGER FILLING TIME	10 min
-----------------------	--------

**Initial fuel feed** - this parameter specifies time, when fuel will be fed before igniter start. Selection of „0s” setting will switch off initial fuel dose feeding. In this case „Fuel dose during ignition” setting shall be programmed as the value over „0%”.

INITIAL FUEL DOSE	10 s
----------------------	------

**Fuel feed cycle** - auger operation cycle includes fuel feeding and feeding pause. This parameter specifies the time of the whole cycle. The desired value specifies all burner work modes which require fuel feeding (ignition, maximum and minimum power).

FUEL FEED CYCLE	15 s
--------------------	------

**Fuel feed during ignition** - this parameter specifies fuel dose that is fed to the burner during lighter operation. The programmed setting specifies feeding time in percent in relation to the time of whole work cycle. Selection of „0s” setting will switch fuel feeding during operation of the lighter. In this case „Initial Fuel Dose” setting shall be programmed as the value over „0s”.

FUEL DOSE DURING IGNITION	20 %
------------------------------	------

**Fuel feed for max. burner power** - this parameter specifies fuel dose fed to the burner during operation with maximum power. The programmed setting specifies feeding time in percent in relation to the time of whole work cycle.

FUEL DOSE FOR MAX POWER	50 %
----------------------------	------

**Fuel feed for min. burner power** - this parameter specifies fuel dose fed to the burner during operation with minimum power. The programmed setting specifies feeding time in percent in relation to the time of whole work cycle.

FUEL DOSE FOR MIN POWER	20 %
----------------------------	------

**Stoker work mode** - this parameter specifies work mode of the stoker:

- „OFF” - the burner without the stoker.
- „CYCL.” - stoker is switched on periodically, regardless of the auger. Work and pause time of the stoker is determined with particular settings.
- „AUTO” - operation mode when the stoke is switched on along with the auger and is switched off with a delay defined with „Stoker extra work time” setting.

STOKER WORK MODE	AUTO
---------------------	------

**Stoker work time** - this parameter specifies operation time of the stoker in whole work cycle. This setting is unavailable if the stoker is switched off or in automatic mode.

STOKER WORK TIME	3 s
---------------------	-----

**Stoker pause time** - this parameter specifies pause time during stoker operation when in work cycle. This setting is unavailable if the stoker is switched off or in automatic mode.

STOKER PAUSE TIME	3 s
----------------------	-----

**Stoker extra work time** - this parameter is available only, when the stoker works in automatic mode and it specifies stoker work time after auger switching off.

STOKER EXTRA WORK TIME	2 0 s
---------------------------	-------

**Stoker emptying time** – this parameter specifies time needed for removal of the whole fuel from the stoker. Stoker emptying during extinguishing of feeder, feeding initial fuel dose (portion), and during burner shut down. This setting is unavailable if the stoker is switched off.

STOKER EMPTYING TIME	4 0 s
-------------------------	-------

**Auger ignition test** - this parameter provides functionalities of „X” emergency input. If „NO” setting was selected then „X” input will be used for connection of e.g. auger flap opening contact sensor or the contact informing on operation of auger motor overload switch. If „YES” setting was selected then „X” input will be used for connection of auger temperature sensor used for ignition detection.

AUGER IGNITION TEST	YES
------------------------	-----

**CAUTION!** In case emergency input is not used, „NO” parameter shall be selected in „Auger ignition test” setting and contacts of „X” input shall be closed.

**Auger ignition temperature** - this parameter specifies auger temperature, when the controller activates auger ignition alarm. This parameter is unavailable when „NO” was selected in „Auger ignition test” setting.

AUGER IGNITION TEMPERATURE	8 0 c
-------------------------------	-------

#### 5.4. Fuel ignition, extinction (shut down) and cleaning combustion chamber.

**Flame detector** - flame detection may follow with two methods: burner temperature measurement or brightness measurement. In case when temperature sensor is used, depending on its location, temperature measurement range may be from several degrees to several hundred degrees. If measured temperatures do not exceed 100°C it is recommended to use CT-1 or CT-2 sensor. In case of higher temperatures, PT-1000 sensor shall be used. For flame brightness measurement, FD-1 optical detector shall be used.

FLAME	
DETECTOR	FD - 1

**Indication correction of flame optical detector** - only when flame optical detector (FD-1) is on. Describes light intensity detected by optical detector when burner is off. The correction value is deducted from the value light intensity during the flame detection. Correction allows calibration of FD-1 sensor the way that during burner shut down value (no flame) of the light equals zero.

FD - 1	
CORRECTION	0

**Hysteresis loss of flame** - depending on the type of flame detector, this parameter specifies how many degrees or units in relation to the threshold set by the user must cut off the lighter or the brightness of the flame temperature to the controller began to flame failure detection procedure.

FLAME VANISH	
HYSTERESIS	10

**WARNING!** If the hysteresis is larger than the threshold of igniter shut down, flame failure detection procedure is started when the temperature drops or the brightness of the flame to the value of „0”.

**Flame failure detection delay** - this parameter specifies how long after the launch procedures for the detection of flame failure or brightness temperature must remain below the hysteresis for the regulator to decide that the furnace was extinguished.

FLAME VANISH	
DELAY	60 s

**Fuel ignition time** - after igniter and fan are switched on, the controller tests temperature increase or brightness in the selected location of the burner. If flame is not detected within the time programmed in this parameter, the controller will repeat ignition cycle.

FUEL IGNITION	
TIME	3 min

**Ignition try count** - this parameter specifies how many times ignition may fail until the controller activates „Out of fuel alarm” and switches into STOP mode. The alarm is indicated with adequate message displayed on the display. To start the controller first refill the fuel, then cancel by pressing STOP button and start setting mode by pressing START button.

IGNITION TRY	
COUNT	2

**Furnace extinction (shut down) time** - if the controller switches to extinction (shut down) mode, the induction fan is activated according to power selected in „Fan speed at extinction (shut down)” setting. After burner extinction (flame loss), the fan operation follows according to time programmed in this setting. This function ensures combustion of all fuel remains and burner cool down.

FURNACE EXTINC.	
TIME	5 min

**Furnace cleaning mode** - this parameter specifies the way the cleaning mechanism works.

- „**NONE**” - means that the burner does not have a cleaning mechanism. In this case, the output DATA is working as an external alarm.

- „**CYCL.**” - means the mode in which the cleaning procedure is run after the firing and repeated at regular intervals until burner shut down is completed. Cleaning procedure is attached to the time set in parameter „Cleaning mechanism work time”. After turning off the regulator, output deducts the time set in parameter „Cleaning mechanism retraction time” and the time set in parameter „Cleaning mechanism pause time”.

- „**AUTO**” - means the cleaning procedure is started automatically after a specified number shut downs or after a sufficient burner operation time. Automatic cleaning means: burner shut down and start cleaning mechanism for the time set in parameter „Cleaning mechanism work time”. After turning off the regulator, output deducts the time set in parameter "Cleaning mechanism retraction time” and then goes to normal working cycle.

HEARTH	
CLEANING	AUTO

**Cleaning mechanism work time** - this parameter is available only when the cleaning mechanism is activated (AUTO or CYCL. mode). It defines the time needed to complete the full mechanism to open or move to end position.

MECHANISM WORK	
TIME	120 s

**Cleaning mechanism retraction time** - this parameter is available only when the cleaning mechanism is activated (AUTO mode, or CYCLE). It specifies the time required for the mechanism retraction to the rest position after turning off the control output.

MECHANISM RETURN TIME	1 2 0 s
--------------------------	---------

**Cleaning mechanism pause time** - this parameter is available only when the cleaning mechanism operates in CYCLE time. It specifies the time interval between successive repetition of the cleaning cycle.

MECHANISM PAUSE TIME	1 2 0 s
-------------------------	---------

**Number shut downs before cleaning** - this parameter is available only when the cleaning mechanism operates in AUTO mode. Specifies which in turn start an extinction cleaning procedure.

EXTINCTION COUNT BEFORE CLEAN	5
----------------------------------	---

**Minimum operating time without cleaning** - this parameter is available only when the cleaning mechanism operates in AUTO mode. Specifies the minimum number of hours the burner must in order to start cleaning. If the minimum time is not reached, the cleaning will not run even if there was a required number of shut downs. Setting the parameter to „0h" control the minimum time off work without cleaning.

MIN WORK WITHOUT CLEANING	2 h
------------------------------	-----

**The maximum working time without cleaning** - this parameter is available only when the cleaning mechanism operates in AUTO mode. Specifies how many hours the burner can work without cleaning. If the maximum time is reached, the cleaning will run even if there was no required number of shut downs.

MAX EORK WITHOUT CLEANING	1 2 h
------------------------------	-------

## 5.5. Central heating pump work parameters.

**Central heating pump switching on parameters** - this parameter specifies the method of central heating pump switching on. Selection of „THERMOSTAT" setting means that central heating pump will be switched on only if room thermostat contacts are closed and in case of emergency (e.g. boiler overheating). Selection of „AUTO" setting means that central heating pump operation will follow regardless of room thermostat.

CH PUMP WORK
MODE AUTO

**Central heating (CH) pump periodic switching on** - this parameter enables periodic operation of central heating pump and water transfer in the heating circuit. The pump is activated periodically every 30 seconds according to selected time in „CH pump periodic work” setting. This function is available, if „THERMOSTAT” was selected in CH pump work mode

CH PUMP PERIODIC
WORK YES

**CH pump periodic work time** - this parameter is available, if CH pump works in „THERMOSTAT” mode and the function of CH pump periodic work is active. The programmed setting will specify the time lapse between CH pump work, in case of opened contacts of the room thermostat.

CH PUMP PERIODIC
WORK TIME 2 m i n

### 5.6. Setting domestic water pump parameters.

The controller offers an additional function for heating of domestic water. Not every heating system is provided with domestic water tank and charge pump, this circuit may be switched off or used for control of the pump that mixes the return water in the boiler.

**Domestic water path** - if „NONE” is selected the domestic water pump is off. In this case temperature sensor input and pump control output may remain disconnected. Selection of „EXISTS” setting provides for interlock release of all parameters and functions related to domestic water path handling. Election of „MIXING PUMP” setting will switch domestic water in the circuit purposed for control of the mixing pump. In this case return water temperature sensor shall be connected instead of domestic water sensor, and the mixing pump instead of charge pump of domestic water tank.

HOT WATER PATH
EXISTS

**Domestic water heating hysteresis** - this parameter indicates water temperature drop in the tank in relation to the programmed setting (so that charge pump was switched on). This setting is available, if domestic water path „EXISTS” setting was selected.

HW HEATING
HYSTERESIS 5 c

**Increase temperature during domestic water heating** - Closing thermostat contacts means that boiler operation will follow according to the temperature programmed with the thermostat knob. If domestic water tank heating is necessary, the desired boiler temperature is higher in relation to the desired domestic water by the selected value in this setting. In case of simultaneous operation of the room thermostat and domestic water tank heating, the controller operation will follow to maintain the higher boiler temperature. This setting is available, if domestic water path „EXISTS” setting was selected.

I N C R E A S E   T E M P .   O N
H W   H E A T I N G                    5 c

**Domestic water pump work extension** - quick switching off of the pump refilling domestic water tank may result in excessive rise of boiler temperature. This parameter enables switching on of domestic water pump extension. This setting is available, if domestic water path „EXISTS” setting was selected.

H W   P U M P   W O R K
E X T E N S I O N                    Y E S

**Domestic water pump extension time** - this parameter specifies the time lapse when domestic water is switched off since the moment when the programmed temperature of domestic water tank was obtained. This setting is available, if domestic water path „EXISTS” setting was selected and pump extension was selected.

H W   P U M P   E X T E N D
T I M E                                    2 m i n

**Mixing pump engaging temperature** - this parameter specifies required return water temperature so that the mixing pump engagement follows the controller. This parameter is available if domestic water path „MIXING PUMP” setting was selected.

M I X I N G   P U M P
E N G A G E   T E M P                    5 0 c

**Mixing pump work hysteresis** - this parameter specifies required return water temperature increase in relation to the mixing pump engagement temperature so that the controller switches off the mixing pump. This parameter is available if domestic water path „MIXING PUMP” setting was selected.

M I X I N G   P U M P   W O R K
H Y S T E R E S I S                    5 c



## 5.7. Boiler work parameters.

**Minimum boiler temperature** - this parameter specifies boiler temperature when the controller shall switch off central heating and domestic water pumps. It is the lowest temperature setting of the boiler that can be programmed with thermostat's knob.

MINIMUM BOILER TEMPERATURE 1 0 0 c
---------------------------------------

**Maximum boiler temperature** - this parameter specifies boiler max. programmed temperature setting which can be programmed with thermostat's knob. It is also boiler temperature when central heating pump is engaged to provide protection for the boiler against overheating.

MAXIMUM BOILER TEMPERATURE 3 0 0 c
---------------------------------------

**Boiler upper hysteresis** - if the controller works in burner minimum power mode, and boiler temperature increase follows by this programmed setting, the controller will start burner extinction(shut down).

BOILER UPPER HYSTERESIS 5 c
--------------------------------

**Burner power switching hysteresis** - when the programmed boiler water temperature is obtained the controller is switched to minimum power work mode. This parameter specifies required water temperature drop so that maximum power work mode was activated. After switching to maximum power the fuel and air feeding dose is determined according to burner power modulation.

BURNER POWER SW. HYSTERESIS 1 c
------------------------------------

**Boiler protection hysteresis** - the controller provides for boiler minimum and maximum temperature by providing control over operation of central heating and domestic water pumps. This parameter specifies hysteresis parameter of boiler limit temperatures switching off.

BOILER PROTECT. HYSTERESIS 2 c
-----------------------------------

**Boiler overheating temperature** - this parameter specifies boiler water temperature when the controller switches off control and activates boiler overheating alarm.

BOILER OVERHEAT TEMPERATURE 3 1 0 c
--

**Burner power modulation** - when modulation is switched on it will results in gradual reduction of fan speed and fuel dose to obtain boiler water temperature corresponding to the programmed setting.

BURNER POWER MODULATION	YES
----------------------------	-----

**Burner power modulation factor** - this parameter specifies degree setting when the controller will reduce burner power before boiler water temperature is obtained according to the programmed setting. Burner power is reduced by gradual reduction of fed fuel dose and fan speed reduction. This parameter is unavailable, if burner modulation power is off.

MODULATION FACTOR	5
----------------------	---

### 5.8. The room thermostat.

RK-2006SPGM was equipped with an input for connecting any room thermostat with contact output. Contacts of the thermostat is signaled by the appearance of the thermometer symbol in the index of the thermostat. CAUTION! The entrance of the room thermostat is active only during WINTER. Lights up when the input state is independent of the mode setting.

**Mode of operation of the room thermostat** – this parameter determines the impact of the entry of the room thermostat to the operation of the controller:

**NORMAL** – in this mode, the thermostat contacts are closed when the controller starts firing up the burner and the boiler strives to maintain the set temperature of the boiler thermostat knob. After reaching the desired temperature in the room and the thermostat regulator contacts open burner extinguishes and goes STANDBY.

**ADAPTATION** – in this mode, the controller analyzes the changes in the thermostat input and based on automatically determines the setpoint temperature of the boiler.

**CAUTION!** In the case of not using the room thermostat input should remain closed, and the operation of the thermostat set to the NORM .. In this case, the boiler will operate continuously maintaining the set temperature of the boiler thermostat knob.

**The time constant of adaptation** – this parameter is available when the thermostat s working in adaptive mode. It determines the rate of "seeking" appropriate adaptive algorithm preset boiler temperature. Value should be selected empirically according to the characteristics of the controlled object. If you are working adaptive algorithm and frequently changing external conditions we observe frequent overheating of the rooms, increase the time constant. During value should be reduced.

**Burner off delay** – this parameter determines the time of the burner in minimum power the thermostat contacts open. If, after the programmed time the thermostat input will not be closed again, the torch will be lit, and the controller switches to STANDBY. Setting this parameter to 0 minutes will immediately extinguish the torch after contact opening thermostat.

**CAUTION!** If the controller works well for hot water, the burner after contact opening the thermostat can be switched off after a time other than that programmed in the parameter

**5.9. Service settings.**

If „YES” selection followed and was confirmed with OK button when this option is displayed will result in cancelling of all parameters and restoration of default parameters programmed before by the fitter or technician.

S E R V I C E	
S E T T I N G S	N O

**CAUTION!** Activation of this function will result in restoration of service parameters for current fuel type only.

**5.10. Output testing.**

It is possible to test particular preset functions. This is available, only, if the controller is in STOP mode before switching to service mode. To select outputs testing option use the knob (12) choosing particular outputs which are indicated by flashing of the proper light and output name displayed. By pressing OK button you can turn on the selected output temporarily. To finish output testing press STOP button.

T E S T I N G	O U T P U T S	
F A N		0

**5.11. Service mode exit.**

By choosing this option and confirmation with OK button you can exit service mode. The controller also exits the service mode, if no button is pressed after 60 seconds.

-- E X I T --
---------------

**6. DATA emergency output** – audible alarm or cleaning mechanism.

The regulator has output DATA allows you to connect via the UM-1 module siren alarm or additional cleaning mechanism. If you exit this mode, the siren is in alarm, it is activated in the event of: sensor failure of the boiler, burner sensor, the sensor or mixing pump hot water, boiler overheating or lack of fuel.

## 7. Controller disassembly.

If controller disassembly is necessary follow the following procedure:

- Disconnect the boiler and controller from power supply,
- Remove the controller from the boiler,
- Disconnect terminals and wires from the controller.

## 8. Technical Data.

Power Supply	230V ± 10%, 50Hz
Power consumption (without fan and pump)	< 4VA
Burner temperature measurement range (KTY 81-210)	-9–109°C ±1°C
Temperature measurement range (KTY 81-210)	-9–109°C ±1°C
Burner temperature measurement range (PT-1000)	-30–500°C ±3°C
Boiler temperature adjustment range	30–90°C ±1°C
Boiler programmed overheating protection	90–99°C ±1°C
Boiler equipment overheating protection	>95°C ±1°C
Total outputs rating	max 4A/230V
Dimensions (H x W x D)	96x144x94

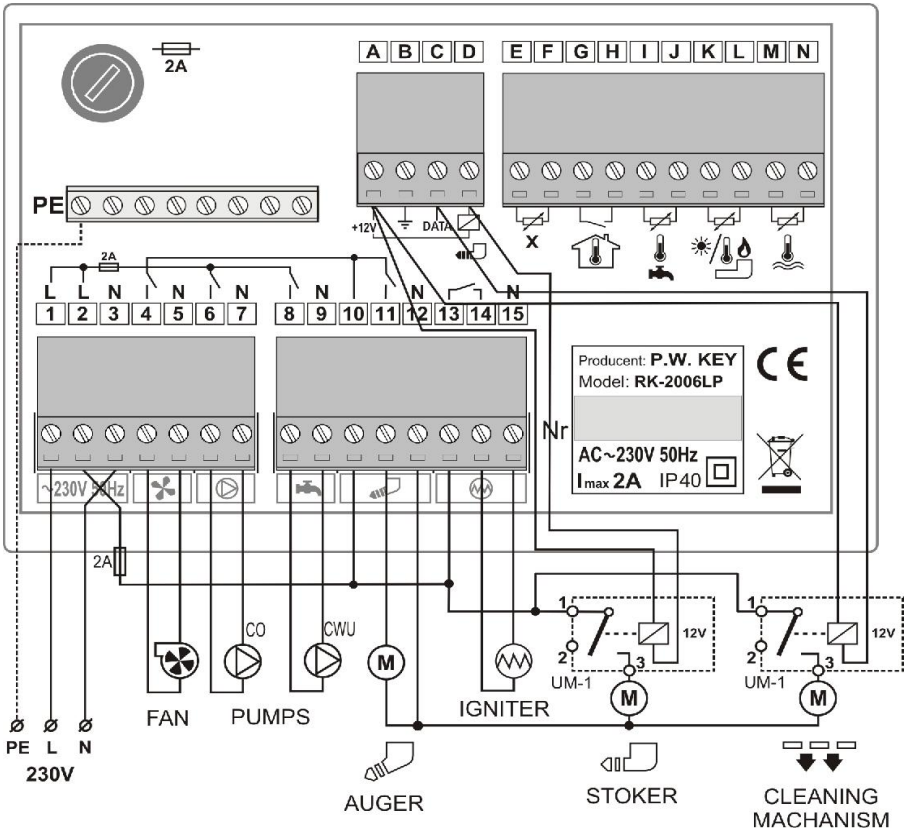

Figure 2. RK-2006LPP Controller connection diagram.

**10. Notes.**

Light	Parameter	Settings.			
		1	2	3	4
Thermostat	Boiler max. power.				
HTW pump	Domestic water desired temperature.				
	Domestic water heating priority.				
Igniter	Brightness when fuel ignition has occurred (FD-1).				
	Burner temperature with fuel ignited (PT-1000, CT-1/2).				

Light	Parameter	Settings			
		1	2	3	4
Fan	Fan modulation during boiler start.				
	Min. fan speed during heating up.				
	Max. fan speed during heating up.				
	Ignition modulation start delay.				
	Fan speed during ignition.				
	Fan speed at max. power.				
	Fan speed at min. power.				
	Fan speed at extinction.				
	Fan speed during cleaning mode.				
	Fan scavenge(air purging).				
	Fan scavenge (air purging) blow time.				
	Fan scavenge(air purging) pause time.				
	Fan speed during scavenge.				
	Auger	Auger filling time.			
Initial fuel feed.					
Fuel feed cycle.					
Fuel feed during ignition.					
Fuel feed for max burner power.					
Fuel feed for min. burner power.					
Stoker work mode.					
Stoker work time.					
Stoker pause time.					
Stoker extra work time.					
Stoker emptying time.					
Auger ignition test.					
Auger ignition temperature.					
Igniter		Flame detector type.			
	Correction FD-1.				
	Hysteresis loss of flame (optical sensor).				

Light	Parameter	Settings			
		1	2	3	4
Igniter	Hysteresis loss of flame (temperature sensor).				
	Flame failure detection delay.				
	Fuel ignition time.				
	Ignition try count.				
	Furnace extinction time.				
	Furnace cleaning mode.				
	Cleaning mechanism work time.				
	Cleaning mechanism retraction time.				
	Cleaning mechanism pause time.				
	Number shut downs before cleaning.				
	Minimum operating time without cleaning.				
	Maximum working time without cleaning.				
	CH pump	Central heating pump work mode.			
Central heating pump periodic work.					
Central heating pump periodic work time.					
HTW pump	Domestic water path.				
	Domestic water heating hysteresis.				
	Boiler increase temperature during hot tap water heating.				
	Domestic pump work extension.				
	Domestic pump work extension time.				
	Mixing pump engaging temperature.				
	Mixing pump work hysteresis.				
Thermostat	Boiler minimum temperature.				
	Boiler maximum temperature.				
	Boiler upper hysteresis.				
	Boiler power switching hysteresis.				
	Boiler protection hysteresis.				
	Boiler overheating temperature.				
	Burner power modulation.				









## DECLARATION OF CONFORMITY

Manufacturer: Przedsiębiorstwo Wielobranżowe KEY  
11-200 Bartoszyce, ul. Bohaterów Warszawy 67

hereby declares that the product:

### **RK-2006LPP Controller**

is in conformity with provisions of the following directives:  
73/23/EWG i 93/68/EWG (LVD 73/23/EEC + 93/68/EEC),  
as superseded by Directive 2006/95/WE (EC Directive 2006/95/EEC);  
89/336/EWG (Elektromagnetic Compatibility Directive 89/336/EEC),  
as amended by Directive 93/68/EWG (EMC Directive 93/68/EEC)

on basis of compliance with the following harmonised directives:

PN-EN 55022:2006(U)  
PN-EN 61000-4-2:1999+A2:2003  
PN-EN 61000-4-3:2006(U)  
PN-EN 61000-4-6:1999+A1:2003+IS1:2006  
PN-EN 61000-4-4:2005(U)  
PN-EN 61000-4-5:2006(U)  
PN-EN 61000-4-11:2005(U)

PN-EN 60730-1:2002+A1:2006(U)A12:2004+A13:2005  
PN-EN 60730-1:2005+A14:2006  
PN-EN 60730-2-9:2006  
PN-EN 61000-3-2:2006(U)  
PN-EN 61000-3-3:1997+A1:2005+A2:2006+IS1:2006

## Information on disposal

This appliance is marked according to the European Directive 2002/96/EC on Waste Electrical and Electronic Equipment (WEEE).



The symbol on the product, or the documents accompanying the product, indicates that his appliance may not be treated as household waste.

The appliance shall be handed over to the applicable collection point for used up electrical and electronic equipment for recycling purpose.

Ultimate disposal of the appliance shall follow according to applicable local regulations on waste utilization. For more information about disposal, utilization and recycling please contact your local authorities, household waste disposal service or the shop where you purchased the product.

Manufacturer: Przedsiębiorstwo Wielobranżowe KEY  
11-200 Bartoszyce, ul. Bohaterów Warszawy 67  
tel. (89) 763 50 50, fax. (89) 763 50 51  
[www.pwkey.pl](http://www.pwkey.pl) e-mail: [pwkey@onet.pl](mailto:pwkey@onet.pl)